

F I R S T . A N D B U I L T T O L A S T .

**KELLEY®**

# **KELLEY CM MECHANICAL DOCK LEVELER**

With premium features such as single point adjustment extension spring counterbalance, unlimited float hold-down and an integral support strut, Kelley's CM Series Mechanical Dockleveler offers the industry a proven design for maximum efficiency and performance.

① Integral lip lock keeps lip raised for routine maintenance and cleaning

② Structural steel safety legs stop dockleveler platform at dock level

③ Working range toe guards. (Full range optional)

④ Unlimited float hold-down provides easy fingertip release and extended float throughout the dockleveler's working range

⑤ Integral support strut with lock-out capability keeps ramp raised for routine maintenance and cleaning

⑥ Open frame design for easy pit cleanout

⑦ Anti-Interference Cam limits safety leg interference throughout the loading/unloading cycle

⑧ Hydra-Cam extends and holds lip at the top of its cycle. Lip remains yieldable throughout loading operation

⑨ Unique oil-tempered, chromium silicone steel extension spring counterbalance with single adjustment point for high strength, durability and easy walk-down

⑩ Lip keepers secure dockleveler when overhead door is down

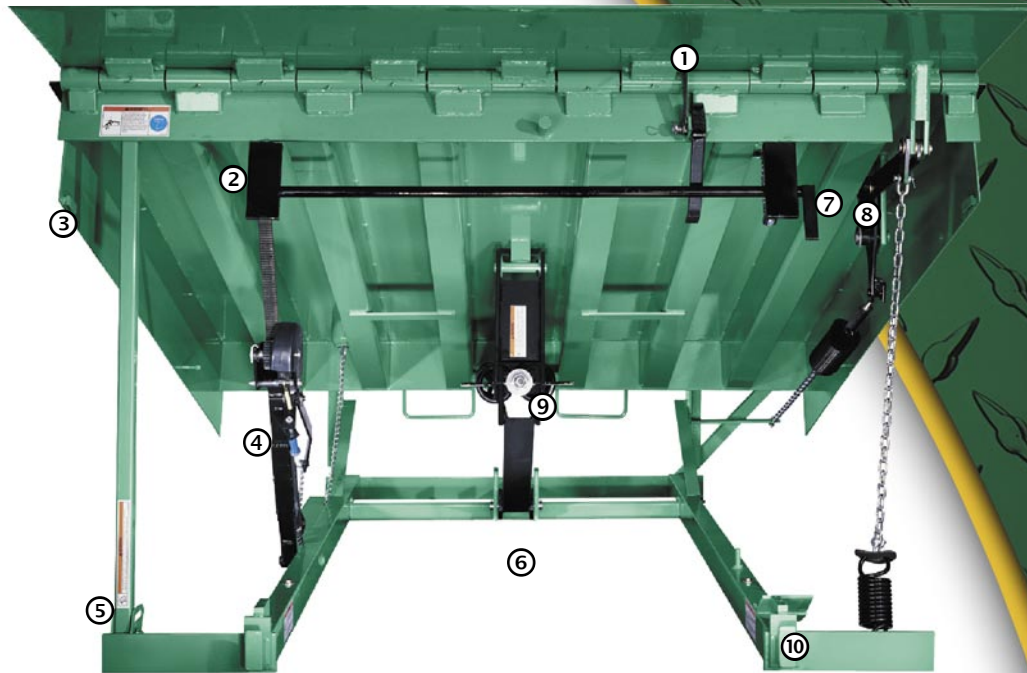

Requires only 10 lbs. of lifting force to release leveler



## Unlimited Float Hold-down

The unlimited float hold-down makes Kelley's CM Dockleveler simple to operate and requires less force to walk down into position to help maximize operational efficiency. This unique design produces less wear on components, is more dependable than ordinary float spring models and has an overall lower lifetime cost of ownership than conventional mechanical docklevelers.

## Hydra-Cam Lip Assembly

The CM Series Dockleveler is equipped with a yieldable lip that gently extends at the top of the upward ramp movement due to a Hydra-Cam lip control mechanism. The lip remains extended until the operator starts to walk the dockleveler down, while a hydraulic shock absorbing cylinder controls the lip's rate of descent as the ramp lowers into position.



## Integrate Your Kelley Equipment For Safer, More Efficient Docks.

Kelley Mechanical Docklevelers can be combined with other loading dock equipment such as trailer restraints, dock doors, dock seals or shelters, dock lights and security systems to improve safety, security, productivity and environmental control on your loading docks.



Kelley products may be covered by one or more of the following U.S. patents or patents pending. (4,776,052 4,847,935 4,928,340 4,937,906 4,961,241 4,974,276 4,977,635 4,979,253 5,001,799 5,042,103 5,088,143 5,097,557 5,117,526 5,157,801 5,303,443 5,313,681 5,396,676 5,459,963 5,446,938 5,460,460 5,471,693 5,75,888 5,481,774 5,500,968 5,511,267 5,522,107 5,522,108 5,526,545 5,544,381 5,553,343 5,586,355 5,586,356 5,600,859 5,651,155 5,774,920 5,802,650 5,802,651 5,813,072 5,826,291 5,831,540 5,832,554 5,881,414 5,926,890 5,996,156 6,006,389 6,035,475 6,125,491 6,327,733 6,360,393 6,370,719 6,405,397 6,460,212 6,487,741 6,594,842 6,711,774)

An SPX Dock Products Company

# KELLEY®

1612 Hutton Dr., Suite 140 / Carrollton, TX 75006 / Tel: 800.558.6960 / Fax: 972.389.4766  
email: [kelleysales@dockproducts.spx.com](mailto:kelleysales@dockproducts.spx.com) [www.kelleycompany.com](http://www.kelleycompany.com)

A continuing research program is in effect at Kelley. We reserve the right to incorporate product improvement at any time without prior notice.

